



NILES®



INSTALLATION GUIDE



FOR USE WITH PLASMA OR OTHER FLAT-PANEL DISPLAY  
MULTI-WAY, HIGH-DEFINITION, WALL-MOUNT LOUDSPEAKERS

**PHD60 PHD42 PHD30**

## CONGRATULATIONS!

Thank you for choosing the **PHD60/42/30 High-Definition, Left/Center/Right Channel, Loudspeaker** from Niles. With proper installation and operation, you should enjoy years of trouble-free use.

Niles manufactures the industry's most complete line of custom installation components and accessories for audio/video systems. To see the complete Niles product assortment, visit us on the Internet at: [www.nilesaudio.com](http://www.nilesaudio.com)

## TABLE OF CONTENTS

|                                    |    |
|------------------------------------|----|
| Introduction                       | 1  |
| Features and Benefits              | 2  |
| Installation Considerations        | 4  |
| Loudspeaker Placement              | 5  |
| Installing the Wall-Mount Brackets | 7  |
| Finishing the Installation         | 9  |
| Operation                          | 13 |
| Specifications                     | 14 |
| Notes                              | 15 |
| Limited Warranty                   | 16 |
| Warranty Registration Card         | 17 |



## INTRODUCTION

The Niles PHD60/42/30 High-Definition, Left/Center/Right Channel, Loudspeaker is expressly designed for superior sonic quality in front left-, center-, or front right-channel applications. It employs advanced technology components that extract the subtle nuances in recorded music or the thunderous action sound in a movie. The PHD60/42/30 is the perfect choice wherever quality of sound is the most important consideration.



**PHD60**



**PHD42**



**PHD30**

---

## FEATURES AND BENEFITS

### **THREE MODELS DESIGNED FOR USE WITH PLASMA OR OTHER FLAT-PANEL DISPLAYS**

The largest model, the PHD60, is designed for use with plasma or other flat-panel displays of 60-inches or more. The PHD42 complements 42-inch and over displays, while the PHD30 works with 30-inches or larger displays. Except for differences in the transducer complement and performance, all three models feature similar technologies. For example: the PHD60 and 42 feature a 3-way loudspeaker design, while the PHD30 features a 2-way design. All offer voice matching sound quality and exceptional detail over a wide listening area.

### **5-1/4-INCH TCC WOOFERS WITH CONE-FORWARD™ DESIGN AND BUTYL-RUBBER SUSPENSION**

The PHD60/42/30 features newly-developed woofer-cone material that combines injection-molded polypropylene with talc, carbon, and ceramic (TCC) stiffening agents. As a result, the cone offers extreme stiffness and light weight for accurate, dynamic response. Our patent-pending Cone Forward™ design positions the woofer cone at the front of the baffle for natural-sounding bass and clear, open midrange response. Additionally, the use of a butyl-rubber suspension offers substantial benefits, including increased movement without mechanical limitations, and improved midrange damping for better detail and clarity.

### **1-1/2-INCH FLUID-COOLED TETERON HYPERBOLIC-DOME MIDRANGE DRIVER**

The PHD60 and PHD42 also feature a Fluid-Cooled Teteron Hyperbolic-Dome Midrange Driver that provides high sound pressures to reproduce critical mid frequencies with exceptional accuracy.

### **1-INCH FLUID-COOLED TETERON TRI-LAMINATE TWEETER**

The PHD60/42/30's Fluid-Cooled Teteron Tweeter employs a tri-laminate design consisting of an inner textile layer, which forms the dome, a high damping layer to eliminate unwanted resonances, and an outside layer of urethane to add stiffness and prevent breakup modes. The result is a transparently clear, sweet, natural-sounding tweeter, which still maintains extended frequency response.

## **ADJUSTABLE, DISPERSION-CONTROLLING MIDRANGE/ TWEETER POD ENABLES PRECISE IMAGING**

The PHD60 and PDH42 each feature a unique Midrange/Tweeter pod that can be rotated and pivoted to enable precise imaging regardless of placement. The pod accommodates vertical or horizontal installations and can be set by the installer after each loudspeaker is mounted. Included are variable treble and midrange level controls for additional response contouring.

## **NILES' HD HIGH-DEFINITION VOICE MATCHING**

Ensures compatibility with other Niles HD High-Definition in-wall, on-wall, and ceiling-mount models to accommodate a wide range of system designs.

## **ADVANCED BASS-REFLEX DESIGN FOR ENHANCED DYNAMIC IMPACT**

The PHD60/42/30's bass-reflex design enhances low-frequency response and dynamic impact. Moreover, the rigid extruded aluminum enclosure helps deliver accurate bass response with low distortion.

## **LOOKS GREAT AND EASY TO INSTALL**

The PHD60/42/30's contemporary finish matches popular flat-panel displays, and its integrated wall mount brackets make installation quick and easy.

## **DOLBY® DIGITAL READY**

The PHD60/42/30 is specifically designed for Home Theater Sound. They are designed to complement and provide for the accurate reproduction of Dolby Digital Encoded Sources.

## INSTALLATION CONSIDERATIONS

### WALL MOUNTING

The Niles PHD60/42/30 loudspeaker is equipped with an included wall-mount bracket for quick and easy installation on a wall. Ideally, a PHD60/42/30 should be placed so that its bracket can be installed on underlying wall studs. If stud mounting is impractical, dry-wall anchors (rated for at least 40 pounds) can be used to mount the loudspeaker between studs (see **INSTALLING THE WALL-MOUNT BRACKETS** on page 7).

### RECOMMENDED AMPLIFIER POWER

For satisfactory performance, we recommend using a home theater receiver (or amplifier) with a power rating of 10 to 250 watts for the PHD60, 10 to 200 watts for the PHD42, and 10 to 150 watts for the PHD30. Most loudspeakers are not damaged by large amplifiers, but rather by small amplifiers. If your system is playing loud music, a small amplifier will run out of power very quickly and can create damaging “clipping” distortions. A more powerful amplifier will play at the same volume without distorting. See **OPERATION** on page 13 for more information about amplifier clipping distortion.

### LOUDSPEAKER WIRE

Use 2-conductor loudspeaker wire when connecting loudspeakers to your receiver or amplifier. For most applications, we recommend using 16- or 18-gauge wire. For wiring runs longer than 80 feet, we recommend 14-gauge wire. The spring-loaded terminals of the PHD60/42/30 will accommodate up to 12-gauge wire directly. Larger sizes can be accommodated via pin connectors.

When running wire inside walls or ceilings, always use (CL-2 or CL-3) rated cable. In some areas, conduit is also required. For a trouble-free installation, low-voltage wire such as loudspeaker wire must be run in accordance with the National Electrical Code and any applicable provisions of the local building code. If you are unsure of the correct installation techniques, wire jacket, or type of conduit to use, consult a professional audio/video installer, building contractor, or the local building and inspection department.

#### TECH TIP

Wire size is expressed by its AWG (American Wire Gauge) number – the lower the number, the larger the wire. For example, 12 AWG is physically larger than 14 AWG.

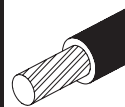

# LOUDSPEAKER PLACEMENT

The Niles PHD60/42/30 loudspeaker is designed for use in front left-, center-, or front right-channel applications. Any model can be wall-mounted using its included wall-mount bracket. For rear-channel applications, we recommend using a Niles HD FX or CM6HDfx loudspeaker.

## PLACING PHD60/42/30'S AS THE FRONT LEFT AND RIGHT LOUDSPEAKERS

In a home theater, the intelligibility of dialog and action reproduced by the front speakers is paramount! The position of the loudspeakers plays a very important role in how clear the sound is and how a stereo image is created.

The PHD60/42/30's are designed specifically for use with plasma or flat-panel displays in a home theater system. The placement process is quick and easy:

- *At the proposed site, make sure the sound will not be blocked or reflected off furniture or other objects. The listener should have a direct line of sight with the front of each loudspeaker. The ideal listening position (e.g., favorite chair or couch) should be centered with the middle of plasma or flat-panel display*
- *Place the speakers with the ports on the bottom on either side of display, as shown in **Figure 1** (also see **INSTALLING THE WALL-MOUNT BRACKETS** on page 7). In applications where there is a center channel, you may choose to space the left and right main speakers farther apart for a "bigger than life" sound with Dolby® encoded movies and TV shows.*

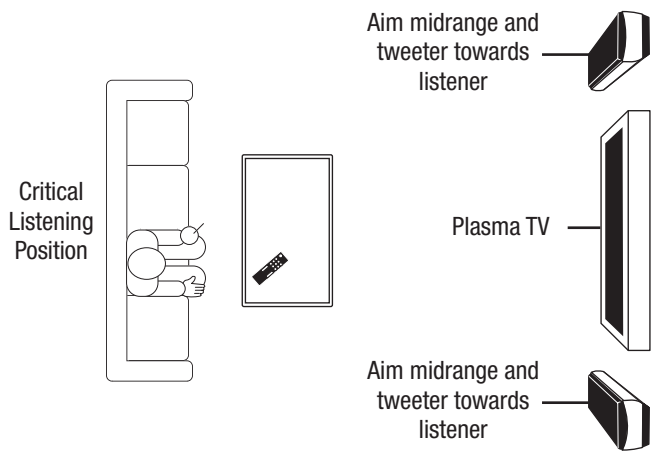

**Figure 1.** Recommended PHD60 loudspeaker placement for front left and right channels is shown here. Placement of the PHD42/30 is similar.

(CONTINUED ON NEXT PAGE)

## PLACING PHD60/42/30'S AS THE FRONT LEFT AND RIGHT LOUDSPEAKERS (CONTINUED)

- As for placement height, place front left and right speakers vertically on either side of the display, so that their tweeters are not more than 24 inches above or below the center-channel loudspeaker's tweeter (see **Figure 2** below).

## PLACING A PHD60/42/30 AS THE CENTER-CHANNEL LOUDSPEAKER

The center-channel loudspeaker is the workhorse in a home theater system. It handles all of the critical dialog and is vitally important in creating the illusion of sounds emanating directly from the picture. Here are some tips for obtaining optimum center-channel performance:

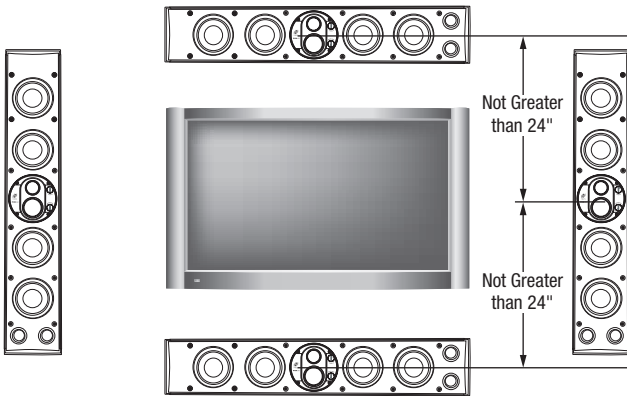

**Figure 2.** Recommended PHD60 loudspeaker placement for the center channel is shown here. Placement of the PHD42/30 is similar.

- In a typical installation, place the PHD60/42/30 horizontally, directly above or below the plasma or flat-panel display. Make sure the loudspeaker is not placed too high or low relative to the left and right speakers, as shown in **Figure 2**.
- For installations where a perforated projection screen will be used, place the PHD60/42/30 with grille removed, either horizontally or vertically, behind the screen at ear level, as shown in **Figure 3**.

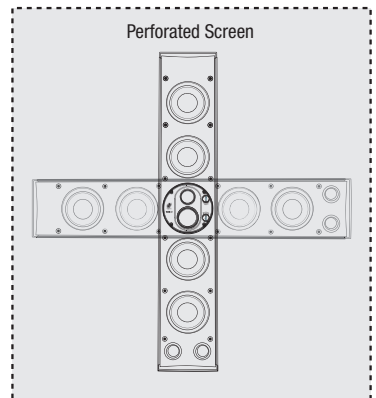

**Figure 3.** Recommended PHD60 center-channel placement with grille removed behind a perforated projection screen is shown here. Placement of the PHD42/30 is similar.



## INSTALLING THE WALL-MOUNT BRACKETS

### TOOLS AND PARTS

We recommend using the following tools and parts to install the PHD60/42/30 wall-mount brackets:

- *Electric drill and drill bits*
- *Philips screwdrivers or driver bit set*
- *Stud finder*
- *Eight wood screws with (optional) dry-wall anchors rated for at least 40 pounds*
- *Pencil*
- *Level*
- *Protective eyewear*

### PRECAUTIONS

Before starting the installation, please observe the following precautions:

- *Turn off all system power before making any connections.*
- *Always wear protective eyewear when using tools.*
- *Make sure hands are clean before installation.*
- *Wear gloves when working with fiberglass insulation.*

### INSTALLATION

1. *At each proposed site, use a stud finder to locate studs (which should be on 16-inch centers) for possible use in the installation. If the studs do not line up with a desired placement location, the PHD60/42/30 wall-mount bracket can still be mounted on a dry wall with appropriate dry-wall screws and anchors.*

**IMPORTANT: DO NOT USE PLASTIC EXPANSION OR THREADED WALL ANCHORS FOR DRY WALL INSTALLATION. CONSULT YOUR LOCAL NILES DEALER OR HOME HARDWARE STORE FOR RECOMMENDATIONS FOR YOUR HOME THEATER APPLICATION.**

*(CONTINUED ON NEXT PAGE)*

## INSTALLATION (CONTINUED)

2. For each loudspeaker, orient and tape the enclosed mounting template to the wall at the desired placement location, as shown in **Figure 4**. Use a level to verify tilt is zero. Be sure to account for any moldings that may interfere with the loudspeaker cabinet upon installation.

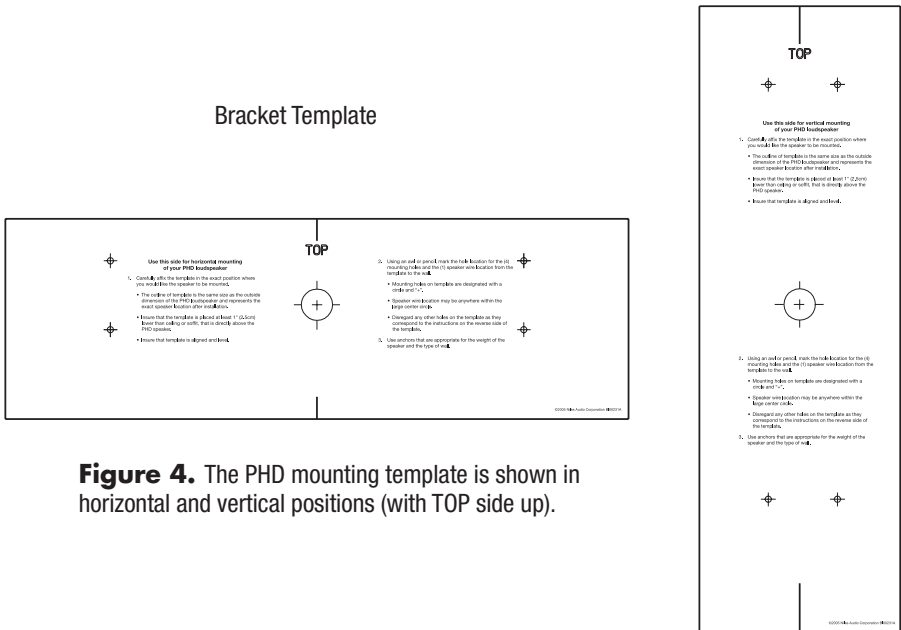

**Figure 4.** The PHD mounting template is shown in horizontal and vertical positions (with TOP side up).

3. Follow the directions included on the template. Drill four small mounting holes at the designated locations noted on the template. If you also plan to run loudspeaker wire in the wall, you'll need to create a cutout for it within the noted wire boundary (see **Figure 4**). When drilling is complete, remove each mounting template.
4. Use the stamped (TOP) label to orient each mounting bracket and run loudspeaker wire through its opening for later connection. Fasten each bracket to the wall with appropriate mounting hardware.



## FINISHING THE INSTALLATION

### CONNECTING THE LOUDSPEAKER

1. At each loudspeaker, separate the loudspeaker wire so that at least 2 inches of each conductor are free. Strip away 1/4 inch of insulation from each loudspeaker wire.
2. On each set of loudspeaker connectors, press down the spring-loaded lever, insert the appropriate conductor, and then release the lever, as shown in **Figure 5**. Gently tug on the loudspeaker wire to make sure it is held in place. If not, repeat this procedure until it is. Make sure that only the bare wire is clamped in the connector.

NOTE: OBSERVE CORRECT POLARITY: POSITIVE (+) GOES INTO THE RED TERMINAL AND NEGATIVE (-) GOES INTO THE BLACK TERMINAL. IF YOU ARE UNSURE OF WIRE POLARITY, SEE THE SECTION **CHECKING LOUDSPEAKER PHASE** ON PAGE 11.

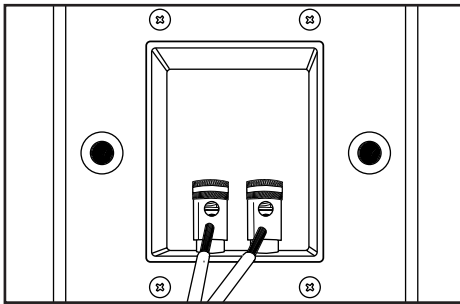

**Figure 5.** Connecting a loudspeaker wire to the PHD60/42/30 terminals.

3. If a mounting bracket was installed on the wall, align each loudspeaker with the two mounting holes (on its bracket) and let it slide down into the keyslot on the bracket to fasten it to the wall, as shown in **Figure 6**.

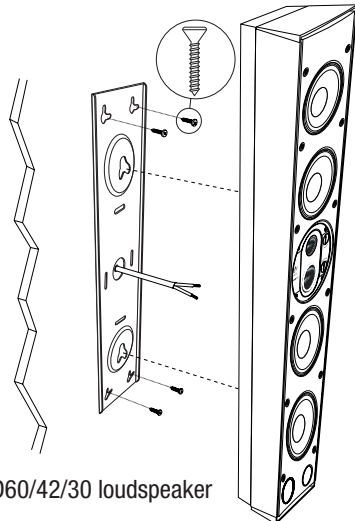

**Figure 6.** Installing a PHD60/42/30 loudspeaker onto its mounting bracket.

(CONTINUED ON NEXT PAGE)

## CONNECTING THE LOUDSPEAKER (CONTINUED)

4. Connect the other end of the loudspeaker wires to the home theater receiver (or amplifier) in the same way as steps 1 and 2.
5. Turn on the home theater receiver and calibrate all loudspeakers in the system according to the receiver manufacturer's instructions.

## PHD60/42: SETTING THE TWEETER/MIDRANGE POD

Each PHD60/42 features an adjustable Tweeter/Midrange Pod on the front baffle for proper loudspeaker orientation and precise imaging, as shown in **Figure 7**. Adjust the pod as follows:

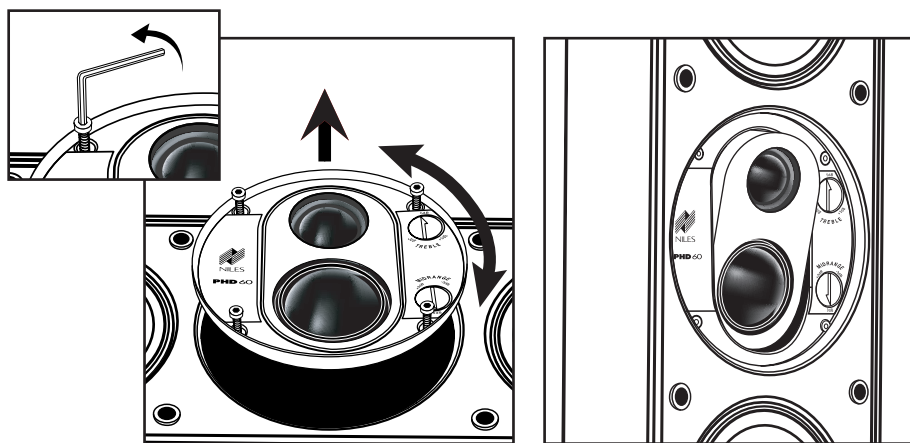
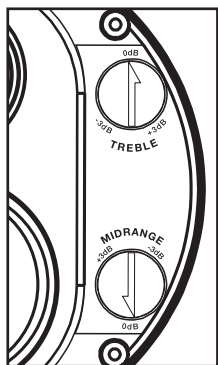

**Figure 7.** Each PHD60/42 includes an adjustable Tweeter/Midrange Pod that can be rotated up to 90 degrees for proper loudspeaker orientation and pivoted for precise imaging.

- For a vertical installation, no adjustments are required. The Tweeter/Midrange pod is optimally set at the factory for this placement.
- For a horizontal installation (e.g., center-channel application), perform the following steps to rotate the Tweeter/Midrange pod:
  1. Using the enclosed Allen wrench, remove the four (4) Allen-head screws, (see **Figure 7**).
  2. Gently pull the pod away from the enclosure and rotate it 90° in either direction (see **Figure 7**). Be careful not to disconnect any attached wires during rotation.
  3. Place the pod back into the enclosure and reinstall the four (4) Allen-head screws.
- If desired, after vertical or horizontal installation, set the imaging by pressing the pod's edge to aim the drivers at the listening position (see **Figure 7**).

## PHD60/42: ACOUSTIC FINE TUNING

Each PHD60/42 also features variable TREBLE and MIDRANGE controls on the front baffle for acoustic fine-tuning after placement, as shown in **Figure 8**. Adjust these controls as follows:



**Figure 8.** Each PHD60/42 includes variable TREBLE and MIDRANGE controls with up to 3 dB of boost or cut in the response.

- *Initially set both TREBLE and MIDRANGE control to 0 dB.*
- *If a PHD60/42 is placed in a room with highly reflective surfaces like glass or tile or the reproduced sound is too bright, decrease the TREBLE setting by as much as -3 dB to lower the high-frequency response. If the room has heavy drapes or is wallpapered, try increasing the TREBLE setting by as much as +3 dB to brighten the high-frequency response.*
- *Listen to dialog being reproduced on the PHD60/42. If you want it more pronounced, increase the MIDRANGE setting by as much as +3 dB to enhance the mid-frequency response. If the dialog is too pronounced, decrease the MIDRANGE setting by as much as -3 dB to lower the mid-frequency response.*

## CHECKING LOUDSPEAKER PHASE

Loudspeaker wire has two conductors. On both your loudspeaker and amplifier, one conductor is attached to the negative (-) terminals, while the other is attached to the positive (+) terminals. Usually, the wire is marked for your convenience, but the marking can be done in the following different ways:

- *Stripe on one wire*
- *Ribbed area you can feel on one conductor*
- *Different colors of metal wire on each conductor*
- *Fabric strand or string wound into one of the conductors* (CONTINUED ON NEXT PAGE)

---

## CHECKING LOUDSPEAKER PHASE (CONTINUED)

Of course, there are some wires that appear completely identical. So be careful, or you might make a connection mistake. If you do, one loudspeaker will be playing “out-of-phase” with the other loudspeaker. A pair of out-of-phase loudspeakers works against each other, and the sound of the two playing together will be lacking in bass and sound “phasey.” If you suspect the sound is not right, and you cannot see any markings on the wire, try this simple test:

1. *Stand halfway between the loudspeakers.*
2. *Play some music with the amplifier or receiver set to Mono.*
3. *Listen to the richness of the bass and the loudness of the sound.*
4. *Turn off the amplifier and reverse the connections on one amplifier channel only.*
5. *Repeat the listening test with the same volume control setting. When the sound has a richer bass and is slightly louder, the loudspeakers are working together or “in-phase.”*

## INSTALLING THE GRILLE

If desired, at each loudspeaker, carefully fit the grille to its cabinet. Starting with one corner, gently press the grille frame around the loudspeaker’s edge, pushing it in at each of the recessed holes.



## OPERATION

### **LISTENING AT HIGHER VOLUMES**

Achieving a reasonable volume of sound in a large room requires more amplifier power than it does in a small room. It is possible to turn the volume up so high that the amplifier runs out of power. This creates “clipping” distortion, which will make treble sound very harsh and unmusical.

When you hear harsh-sounding treble from any good loudspeaker, turn the volume down immediately! Those harsh sounds are masking much more powerful ultra-high-frequency sound spikes, which will quickly damage any fine loudspeaker. You are much less likely to damage a loudspeaker driven by a large amplifier because it will be very loud before any clipping distortion is produced.

### **CLEANING**

To clean the enclosure, use a dampened soft cloth or paper towel. To clean the grille, use a gentle vacuum cleaner.

## SPECIFICATIONS

### PHD60

#### Driver Complement

- Four 5-1/4" TCC Woofers
- 1-1/2" Teteron Midrange with fluid cooling
- 1" Teteron Tweeter with fluid cooling

#### Design Principle

- Bass-reflex design
- 3-way crossover for optimum phase and frequency response
- Adjustable, dispersion-controlling, midrange/tweeter pod

#### Recommended Amplifier Power

10 to 250 watts per channel

#### Nominal Impedance

4 ohms

#### Frequency Response

55 Hz to 21 kHz, +/- 3 dB

#### Sensitivity

90 dB with 2.83 V pink noise input, measured at 1 meter on axis

#### Dimensions (with Wall Bracket)

34.7" H x 6.2" W x 5.6" D

#### Weight

40 lb

#### Wiring Requirements

We recommend using 16- to 18-gauge loudspeaker wire for runs up to 80 feet and 14-gauge loudspeaker wire for runs up to 200 feet. The connectors will accommodate 12- to 22-gauge wire.

### PHD42

#### Driver Complement

- Four 5-1/4" TCC Woofers
- 1-1/2" Teteron Midrange with fluid cooling
- 1" Teteron Tweeter with fluid cooling

#### Design Principle

- Bass-reflex design
- 3-way crossover for optimum phase and frequency response
- Adjustable, dispersion-controlling, midrange/tweeter pod

#### Recommended Amplifier Power

10 to 200 watts per channel

#### Nominal Impedance

4 ohms

#### Frequency Response

63 Hz to 21 kHz, +/- 3 dB

#### Sensitivity

89 dB with 2.83 V pink noise input, measured at 1 meter on axis

#### Dimensions (with Wall Bracket)

24.8" H x 6.2" W x 5.6" D

#### Weight

30 lb

#### Wiring Requirements

We recommend using 16- to 18-gauge loudspeaker wire for runs up to 80 feet and 14-gauge loudspeaker wire for runs up to 200 feet. The connectors will accommodate 12- to 22-gauge wire.

### PHD30

#### Driver Complement

- Two 5-1/4" TCC Woofers
- 1" Teteron Tweeter with fluid cooling

#### Design Principle

- Bass-reflex design
- 2-way crossover for optimum phase and frequency response
- Symmetrical driver configuration for dispersion control and precise imaging

#### Recommended Amplifier Power

10 to 150 watts per channel

#### Nominal Impedance

4 ohms

#### Frequency Response

70 Hz to 21 kHz, +/- 3 dB

#### Sensitivity

89 dB with 2.83 V pink noise input, measured at 1 meter on axis

#### Dimensions (with Wall Bracket)

19.6" H x 6.2" W x 5.6" D

#### Weight

20 lb

#### Wiring Requirements

We recommend using 16- to 18-gauge loudspeaker wire for runs up to 80 feet and 14-gauge loudspeaker wire for runs up to 200 feet. The connectors will accommodate 12- to 22-gauge wire.





## NOTES

---

---

---

---

---

---

---

---

---

---

---

---

---

---

---

---

---

---

---

---

---

---

---

## LIMITED WARRANTY

NILES AUDIO CORPORATION (“NILES”) WARRANTS ITS LOUDSPEAKER PRODUCTS TO THE ORIGINAL PURCHASER TO BE FREE OF MANUFACTURING DEFECTS IN MATERIAL AND WORKMANSHIP FOR A PERIOD OF TWO YEARS FROM DATE OF PURCHASE.

THIS WARRANTY IS SUBJECT TO THE FOLLOWING ADDITIONAL CONDITIONS AND LIMITATIONS. THE WARRANTY IS VOID AND INAPPLICABLE IF NILES DEEMS THAT THE PRODUCT HAS BEEN USED OR HANDLED OTHER THAN IN ACCORDANCE WITH THE INSTRUCTIONS PROVIDED BY THE MANUFACTURER, INCLUDING BUT NOT LIMITED TO DAMAGE CAUSED BY ACCIDENT, MISHANDLING, IMPROPER INSTALLATION, ABUSE, NEGLIGENCE, OR NORMAL WEAR AND TEAR, OR ANY DEFECT CAUSED BY REPAIR TO THE PRODUCT BY ANYONE OTHER THAN NILES OR AN AUTHORIZED NILES DEALER.

TO OBTAIN WARRANTY SERVICE, TAKE THE UNIT TO THE NEAREST AUTHORIZED NILES DEALER, WHO WILL TEST THE PRODUCT AND IF NECESSARY, FORWARD IT TO NILES FOR SERVICE. IF THERE ARE NO AUTHORIZED NILES DEALERS IN YOUR AREA, YOU MUST WRITE TO NILES AND INCLUDE YOUR NAME, ADDRESS, MODEL AND SERIAL NUMBER OF YOUR UNIT, ALONG WITH A BRIEF DESCRIPTION OF THE PROBLEM. A FACTORY RETURN AUTHORIZATION NUMBER WILL BE SENT TO YOU. DO NOT RETURN ANY UNIT WITHOUT FIRST RECEIVING WRITTEN AUTHORIZATION AND SHIPPING INSTRUCTIONS FROM NILES.

IF THE ABOVE CONDITIONS ARE MET, THE PURCHASER’S SOLE REMEDY SHALL BE TO RETURN THE PRODUCT TO NILES, IN WHICH CASE NILES WILL REPAIR OR REPLACE, AT ITS SOLE OPTION, THE DEFECTIVE PRODUCT WITHOUT CHARGE FOR PARTS OR LABOR. NILES WILL RETURN A UNIT REPAIRED OR REPLACED UNDER WARRANTY BY SHIPPING SAME BY ITS USUAL SHIPPING METHOD FROM THE FACTORY (ONLY) AT ITS EXPENSE WITHIN THE UNITED STATES OF AMERICA. THERE ARE NO OTHER WARRANTIES, INCLUDING WITHOUT LIMITATION, EITHER EXPRESS OR IMPLIED WARRANTIES OF MERCHANTABILITY OR FITNESS FOR A PARTICULAR PURPOSE, WITH RESPECT TO THE PRODUCT.

REPAIR OR REPLACEMENT AS PROVIDED UNDER THIS WARRANTY IS THE EXCLUSIVE REMEDY OF THE CONSUMER/ PURCHASER. NILES SHALL NOT BE RESPONSIBLE FOR ANY INCIDENTAL OR CONSEQUENTIAL DAMAGES EXCEPT TO THE EXTENT PROVIDED (OR PROHIBITED) BY APPLICABLE LAW.

SOME STATES DO NOT ALLOW THE EXCLUSION OR LIMITATION OF INCIDENTAL OR CONSEQUENTIAL DAMAGES, SO THE ABOVE LIMITATION MAY NOT APPLY TO YOU. THIS WARRANTY GIVES YOU SPECIFIC LEGAL RIGHTS, AND YOU MAY ALSO HAVE OTHER RIGHTS WHICH VARY FROM STATE TO STATE.

**FOR THE NAME OF YOUR NEAREST AUTHORIZED NILES DEALER CONTACT:  
NILES AUDIO CORPORATION, P.O. BOX 160818, MIAMI, FLORIDA 33116-0818.**

*Please fill in your product information and retain for your records.*

Model \_\_\_\_\_ Serial No. \_\_\_\_\_ Purchase Date \_\_\_\_\_

## WARRANTY REGISTRATION CARD

Model Purchased \_\_\_\_\_

Serial Number \_\_\_\_\_

Date Purchased (month/day/year) \_\_\_\_\_

Dealer Name and Location \_\_\_\_\_

Dr.     Miss     Mr.     Mrs.     Ms.

Name \_\_\_\_\_

Address \_\_\_\_\_

City \_\_\_\_\_ State \_\_\_\_\_ Zip \_\_\_\_\_

Telephone (       ) \_\_\_\_\_

Please take a moment to fill out our warranty registration card. The information helps us to get to know you better and develop the products you want

**Age:**

- Under 25
- 25-34
- 35-44
- 45-54
- 55 & over

**Income:**

- Under \$24,999
- \$25,000-\$34,999
- \$35,000-\$44,999
- \$45,000-\$59,999
- \$60,000-\$74,999
- \$75,000-\$99,999
- Over \$99,999

**Occupation:**

- Arts/Entertainment
- Business Owner
- Engineer
- Finance/Accounting
- General Office
- Management
- Professional
- Sales/Marketing
- Student
- Tradesperson

**Musical tastes:**

- (Please check all that apply)
- Alternative
  - Classical
  - Country
  - Jazz
  - New Age
  - Popular
  - R&B
  - Rock
  - Other \_\_\_\_\_

**How did you hear about Niles?**

- Architect/Developer
- Custom Installer
- Direct Mail
- Friend/Family
- In-Store Display
- Interior Designer
- Magazine Ad
- Mail-Order Catalog
- Newspaper Ad
- Product Brochure
- Product Review
- Retail Salesperson

**What magazines do you read?**

1. \_\_\_\_\_
2. \_\_\_\_\_
3. \_\_\_\_\_

**Who will install the product?**

- Custom Installer
- Electrician
- Friend
- Myself

**Which factor(s) influenced the purchase of your Niles product? (Please check all that apply)**

- Ease of Use
- Price/Value
- Product Features
- Quality/Durability
- Reputation
- Style/Appearance
- Warranty

**Do you . . . ?**

- Own a House. If yes, how many square feet? \_\_\_\_\_

- Own a Town House/Condominium/Co-op
- Rent an Apartment
- Rent a House

- Are you interested in receiving literature on other Niles products?**
- Yes     No

- Are there products/capabilities that you would like to see introduced?**
- \_\_\_\_\_
- \_\_\_\_\_
- \_\_\_\_\_

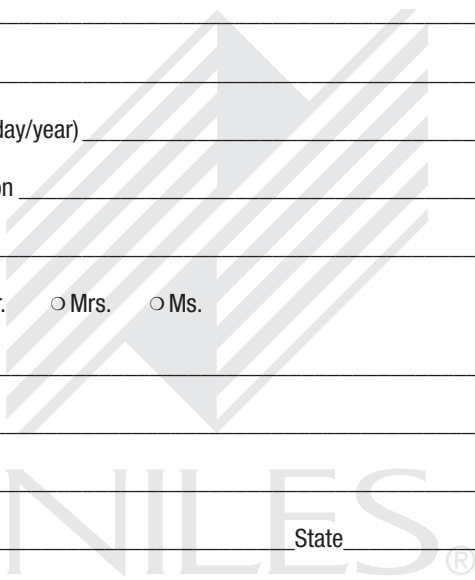

DETACH HERE AND RETURN TO: MILES AUDIO CORPORATION WARRANTY REGISTRATION DEPT. P.O. BOX 160818 MIAMI, FLORIDA 33116-0818



BLENDING HIGH FIDELITY AND ARCHITECTURE®

Niles Audio Corporation  
12331 S.W. 130 Street Miami, Florida 33186  
Designed and Engineered in USA  
Made in China

©2005 Niles Audio Corporation. All rights reserved. Niles, the Niles logos and Blending High Fidelity and Architecture are registered trademarks of Niles Audio Corporation. All other trademarks are the property of their respective owners. 10/05 DS004138CN